

# TECHNICAL DESCRIPTION

## HYDRONIC S3 ECONOMY



**The technical description and installation instructions are valid for the following engine-independent water heaters:**

Heaters for petrol

B 4 E – 12 V CL      20 1963 05 00 00

B 5 E – 12 V CL      20 1952 05 00 00

Heaters for diesel

D 4 E – 12 V CL      25 2694 05 00 00

D 5 E – 12 V CL      25 2652 05 00 00

## 3 INSTALLATION

### HEATER INSTALLATION POSITIONS

The heater should preferably be installed in the normal position. Depending on the installation conditions, the heater can be installed within the allowable swivel ranges.

#### **i** NOTE

In heating mode, the normal and maximum installation positions shown can differ by up to +15° in all directions for a short time. These differences, caused by tilted positions of the vehicle, do not have any negative effects on the heater's function.

#### INSTALLATION POSITION – HEATER UPRIGHT / ON ITS SIDE

The upright installation position (normal position) with swivel range up to the horizontal (heater on its side) installation position is allowable. All installation positions between 0° and 90° are permitted.

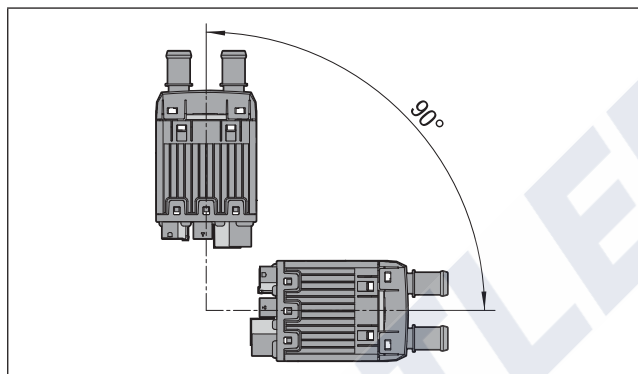

#### **i** NOTE

If a heater is swivelled out of the normal position, the exhaust connections must **always** be at the bottom.

#### INSTALLATION POSITION – HEATER HORIZONTAL / VERTICAL

The horizontal installation position with swivel range up to the vertical installation position is allowed. All installation positions between 0° and 90° are permitted.

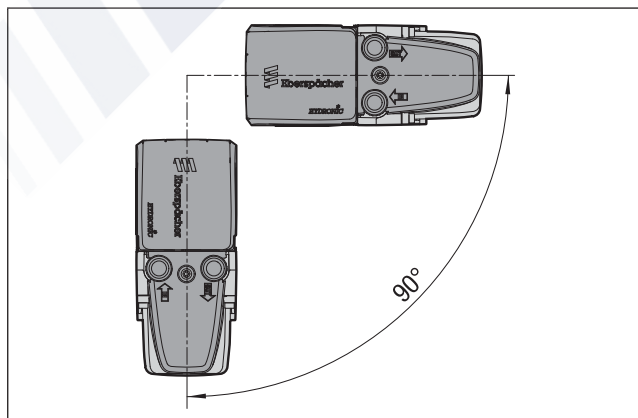

### WATER PUMP INSTALLATION POSITION

Depending on the installation conditions, the water pump can be installed within the allowable swivel ranges, see sketch. The water pump is not self-priming. The water inlet must therefore be arranged so that it is always completely filled with coolant liquid.

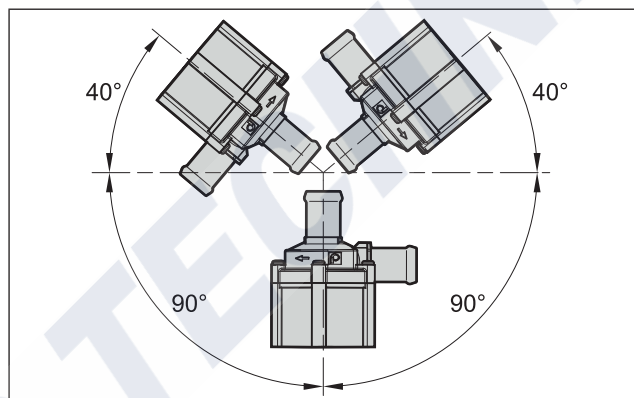

#### **i** NOTE

The installation position of the water pump with the pump head facing downwards is not permissible for automatic venting.

### INSTALLATION LOCATION

The heater and the water pump are installed in the engine compartment.

The heater and the water pump must be installed below the minimum allowable coolant liquid level (header tank, radiator, vehicle's heat exchanger) so that the heat exchanger of the heater and the water pump can vent automatically.

#### **i** NOTE

- Note and observe the relevant regulations and safety instructions [from page 15](#).
- The installation suggestions made in the installation instructions are examples. Other installation locations are possible if they comply with the installation requirements stated in these installation instructions.
- Note and observe the allowable installation positions together with the operating and storage temperatures.
- Ensure adequate distance from hot vehicle parts.
- Do not install the water pump at the lowest point of the coolant liquid circuit, as otherwise the particles in the coolant liquid circuit settle in the water pump.

### 3 INSTALLATION

#### INSTALLATION EXAMPLE: PETROL HEATER IN A CAR

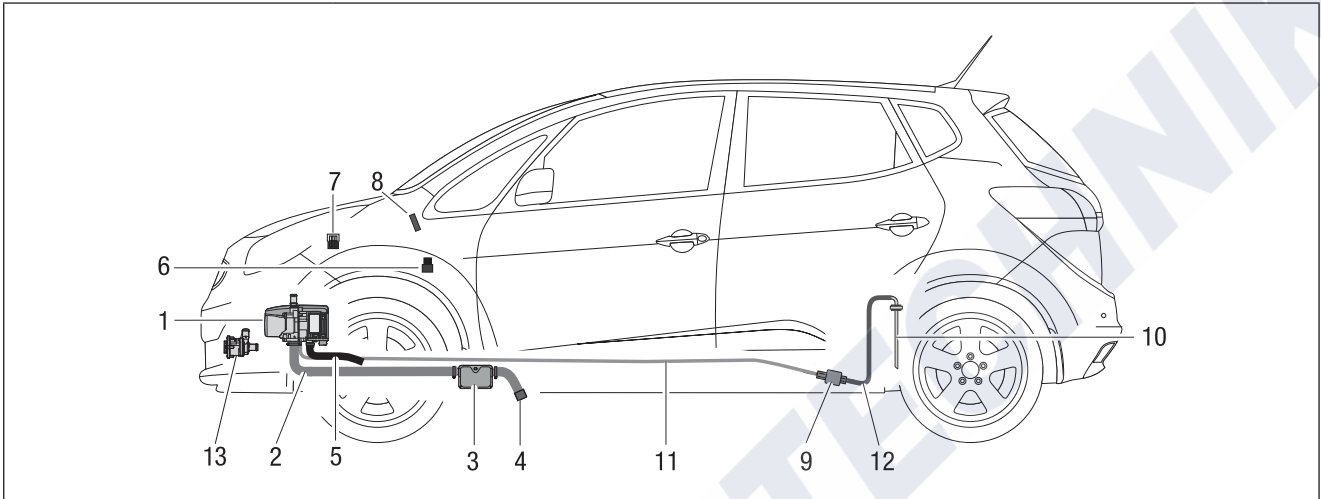

- |                    |                       |                    |                  |
|--------------------|-----------------------|--------------------|------------------|
| 1 Heater           | 5 Combustion air hose | 8 Control unit     | 11 Pressure line |
| 2 Exhaust pipe     | 6 Fan relay           | 9 Metering pump    | 12 Intake line   |
| 3 Exhaust silencer | 7 Fuse bracket        | 10 Tank connection | 13 Water pump    |
| 4 Exhaust pipe end |                       |                    |                  |

#### INSTALLATION EXAMPLE: DIESEL HEATER IN A TRANSPORTER

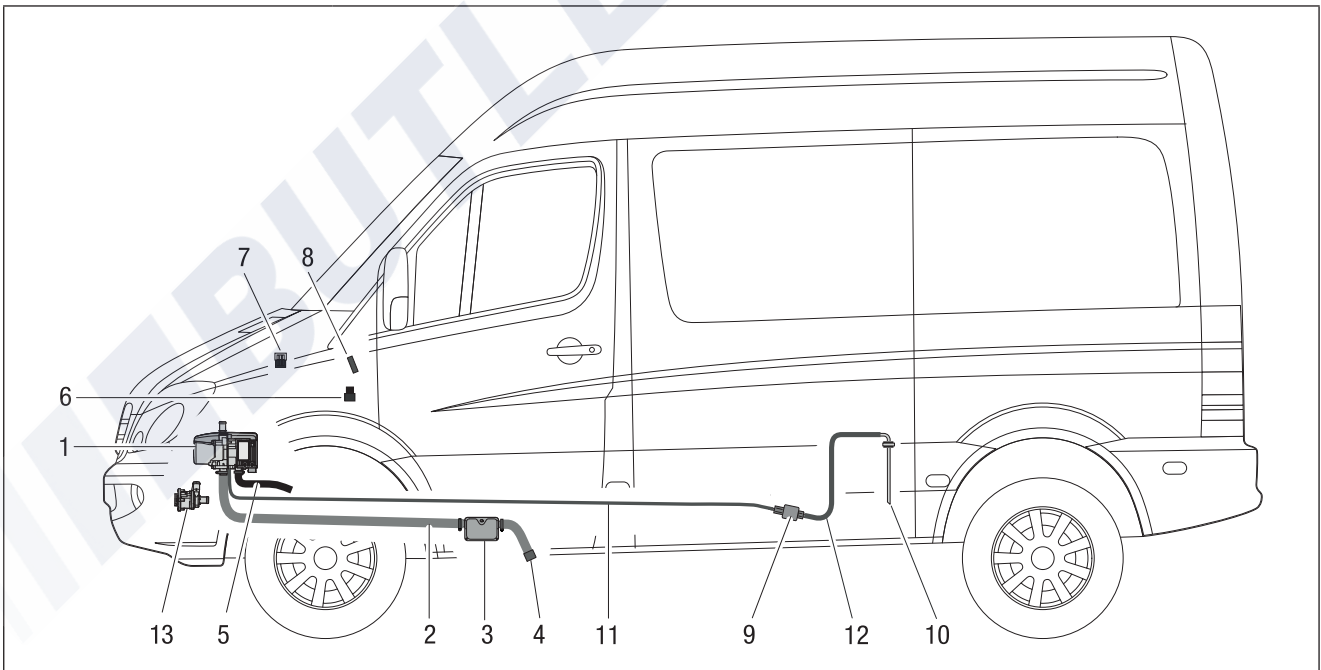

- |                    |                       |                    |                  |
|--------------------|-----------------------|--------------------|------------------|
| 1 Heater           | 5 Combustion air hose | 8 Control unit     | 11 Pressure line |
| 2 Exhaust pipe     | 6 Fan relay           | 9 Metering pump    | 12 Intake line   |
| 3 Exhaust silencer | 7 Fuse bracket        | 10 Tank connection | 13 Water pump    |
| 4 Exhaust pipe end |                       |                    |                  |

## 3 INSTALLATION

### FIXING THE HEATER

Use the bracket included in the installation kit to fix the heater in a suitable position on the vehicle. The installation steps for the diesel and petrol heater are the same.

#### Installation steps

1. Use 4 hexagon screws M6 x 12 and 4 hexagon nuts M6 or 4 thread-forming screws to fix the bracket (tightening torque:  $9^{+1}$  Nm).

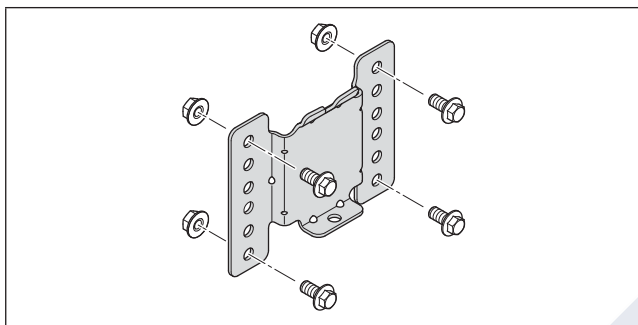

#### **i** NOTE

Preferably use the top and bottom fastening holes, see sketch. If using the other holes, ensure a minimum distance between the fastening screws.

2. Insert the heater in the bracket and fix onto the bracket with one screw M6 x 16, SW T30 (tightening torque:  $10^{+1}$  Nm).

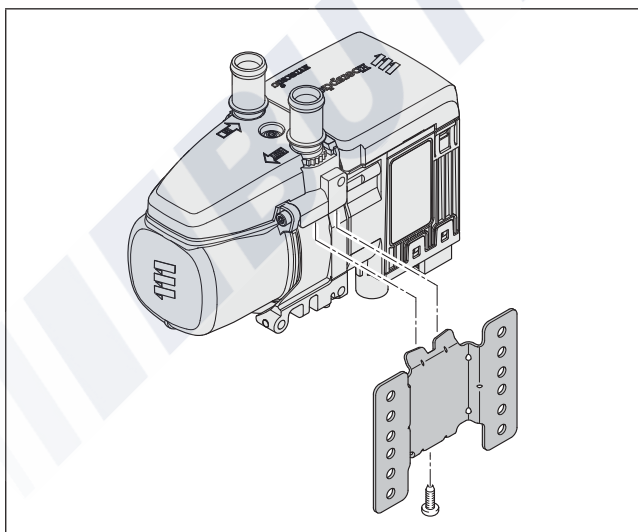

#### **i** NOTE

A thread-forming screw is used to fix the heater onto the standard bracket. It is not necessary to pre-cut a thread. The thread is formed by the screw on screwing it into the tapping hole.

### Installation instructions

- Position screw by hand and screw in.
  - Always keep to the given tightening torque.
- When screwing for the second time also position by hand and do not cut a new thread.
- The screw is suitable for max. 6 installation attempts.
- In case of repair (removal of heater) a metric screw (M6 x 16) can be used as an alternative.

#### **i** NOTE

If a vehicle-specific bracket is used, the three additional thread-forming screws enclosed must be used. Tightening torque:  $10^{+1}$  Nm.

### FIXING THE WATER PUMP

Use the water pump bracket included in the installation kit to fix the water pump in a suitable position on the vehicle. Then insert the water pump in the rubber element and press in until the water pump has latched into position.

### NAMEPLATE

The nameplate (1) is fastened to the side of the heater.

The 2nd nameplate (duplicate) is enclosed with the heater and must be glued onto a readily visible place in the vehicle.

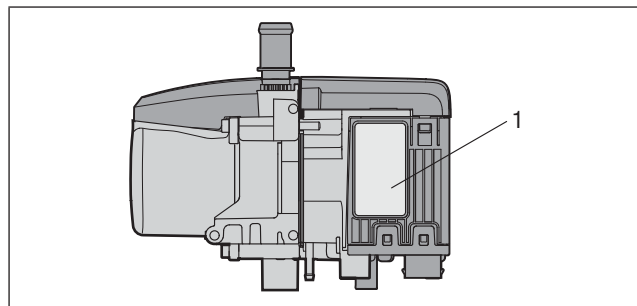

- 1 Nameplate

#### **i** NOTE

Note and observe the relevant regulations [on page 7](#).

### FIXING THE FUSE HOLDER

Use a hexagon screw size M6 x 12 and hexagon nut size M6 to fix the bracket in a suitable position within the vehicle's engine compartment. Fix the fuse holder to the bracket using 2 blind rivets 4 x 8; to do this, press in the bolts of the two split rivets until the fuse holder is installed securely on the bracket.

### 3 INSTALLATION

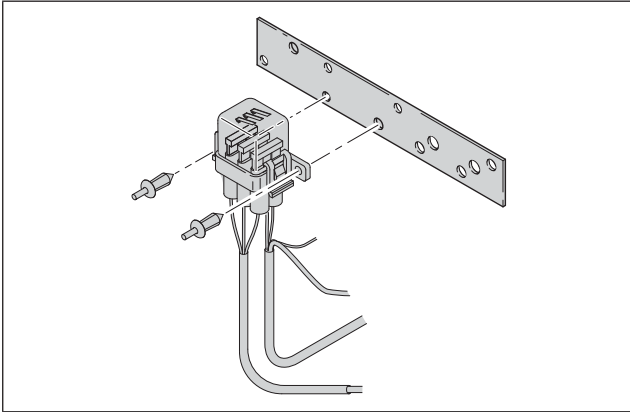

#### FIXING THE FAN RELAY BLOCK

Use a cable tie or blind rivet to fix the fan relay block in a suitable, accessible position inside the vehicle, to do this, push in the bolt of the split rivet 5.5 x 12 until the relay block is securely installed.

#### INSTALLING THE WATER CONNECTION SOCKETS

The heater scope of supply includes two straight water connection sockets and the installation kit includes two angled water sockets. Depending on the installation conditions, the straight water connection sockets (3) and the angled water connection sockets (4) can be installed with the sensor cover.

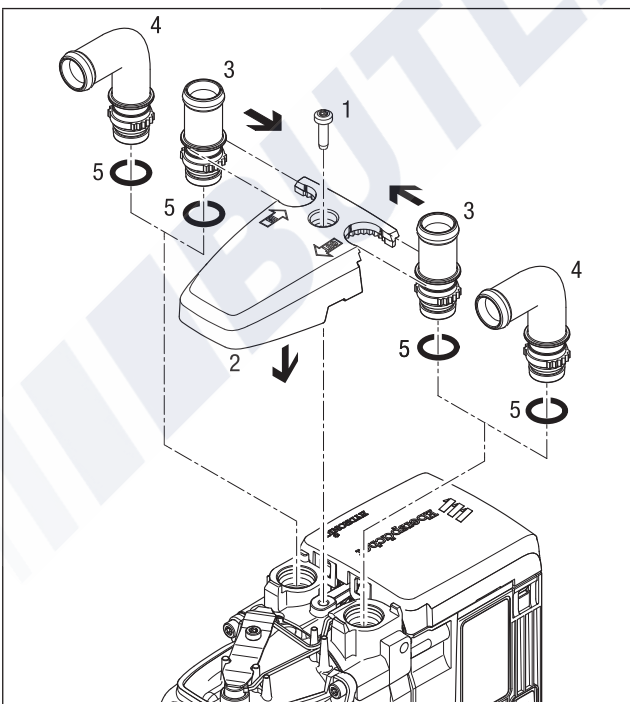

- |                               |                             |
|-------------------------------|-----------------------------|
| 1 Screw M5 x 18               | 4 Connection socket, angled |
| 2 Sensor cover                | 5 O-ring                    |
| 3 Connection socket, straight |                             |

#### Installation steps

- Insert O-ring (5) in the groove of the connection socket.
- Insert connection sockets (3 or 4) in the recesses of the sensor cover (2). The collar at the connection socket is above the cover.
- Position and fix the connection sockets with the teething in the sensor cover.
- Position the sensor cover on the heater with the connection socket first.
- Push the connection socket completely into the connection holes in the heat exchanger.
- Adjust the direction for the angled connection sockets:
  - Lift the sensor cover up to the collar of the connection sockets
  - Turn connection socket in the required direction
  - Push sensor cover downwards and readjust the connection socket position until the teething intermesh once again
- Use screw M5 x 18 to fix the sensor cover (tightening torque  $6.5^{+0.5}$  Nm).

#### **i** NOTE

A thread-forming screw is used to fix the sensor cover. It is not necessary to pre-cut a thread. The thread is formed by the screw on screwing it into the tapping hole.

#### Installation instructions

- Position screw by hand and screw in.
  - Always keep to the given tightening torque.
- When screwing for the second time also position by hand and do not cut a new thread.
- The screw is suitable for max. 6 installation attempts.
- In case of repair (removal of heater) a metric screw (M5 x 18) can be used as an alternative.

#### CONNECTION TO THE COOLANT LIQUID CIRCUIT

#### **⚠ DANGER!**

#### Risk of injury, scalding and burns

**The high temperatures of the coolant liquid and the coolant liquid circuit components can cause injuries, scalds and burns.**

- ➔ Before working on the coolant liquid circuit, wait until all components have cooled, wear safety gloves if necessary.
- ➔ Lay and fix parts carrying coolant liquid in such a way that they pose no temperature risk to man, animals or material sensitive to temperature due to radiation / direct contact.

The heater is integrated in the coolant liquid circuit in the water flow hose from the vehicle engine to the heat exchanger. There are various installation options for this. These are described [from page 19](#).

## 3 INSTALLATION

### **i** NOTE

- When installing the heater, please note the direction of flow of the coolant liquid circuit.
- Fill the heater and water hose with coolant liquid before connecting to the coolant liquid circuit.
- Route the water hoses without any kinks, and in a rising position if possible.
- When laying the water hoses, maintain sufficient distance from hot vehicle parts and sharp edges.
- Protect all water hoses / water pipes from chafing and from extreme temperatures.
- Secure all hose connections with hose clips (tightening torque  $3^{+0.5}$  Nm).
- Re-tighten the hose clips after the vehicle has been running for 2 hours or has travelled 100 km.
- The minimum water flow rate is ensured if, at a cooling water temperature  $> 60$  °C, the temperature difference in the heating medium between the water inlet and water outlet does not exceed 10 K.
- Only overpressure valves with an opening pressure of min. 0.4 – max. 2 bar may be used in the coolant liquid circuit.
- The coolant liquid circuit must contain at least 10 % antifreeze all year round as corrosion protection.
- During cold periods the coolant liquid circuit must contain sufficient antifreeze. Follow the vehicle manufacturer's information regarding the mix ratio.
- Before initial commissioning of the heater or after changing the coolant liquid, the whole coolant liquid circuit including heater must be vented free of bubbles according to the instructions issued by the vehicle manufacturer.
- Only use the anti-freeze approved by the vehicle manufacturer in the allowable mix ratio (anti-freeze/ water).
- Water hoses / water pipes must be securely fixed to prevent damage and / or odour emissions due to vibrations. Recommended guide value: Fix outgoing water hoses / water pipes from the heater at a distance of approx. 20 cm with hose clips, pipe clips or cable ties.

### COOLANT LIQUID CIRCUIT "INLINE INTEGRATION"

Cut the water flow hose from the vehicle engine to the vehicle's heat exchanger.

Use connectors and water hoses to connect the heater and the water pump to the water flow hose.

Lay a water hose from the discharge end of the water pump to the water inlet socket of the heater and connect.

#### Heating characteristics

If the heater is switched on, the heat is initially fed via the heater's own heat exchanger to the vehicle's engine only.

If the coolant liquid temperature reaches approx. 30 °C, the vehicle fan starts and the heat is also routed to the passenger compartment.

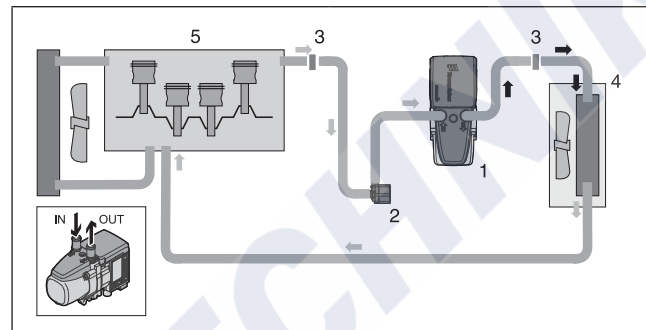

- |              |                  |
|--------------|------------------|
| 1 Heater     | 4 Heat exchanger |
| 2 Water pump | 5 Vehicle engine |
| 3 Connector  |                  |

### COOLANT LIQUID CIRCUIT "INLINE – ENGINE PRE-HEATING ONLY"

Disconnect the water return hose from the heat exchanger to the vehicle engine.

Use connectors and water hoses to connect the heater and the water pump.

#### Heating characteristics

For engine pre-heating only, set the temperature controller to "cold" and switch off the fan. There is thus no heat discharge into the interior of the vehicle.

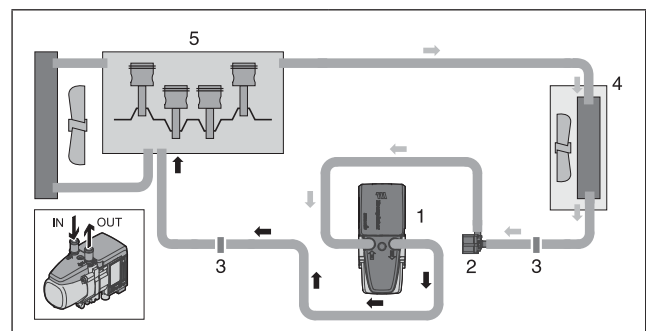

- |              |                  |
|--------------|------------------|
| 1 Heater     | 4 Heat exchanger |
| 2 Water pump | 5 Vehicle engine |
| 3 Connector  |                  |



### 3 INSTALLATION

#### COOLING LIQUID CIRCUIT WITH NON-RETURN VALVE AND THERMOSTAT

Cut the water flow hose from the vehicle engine to the vehicle's heat exchanger and insert the non-return valve.

Cut the water return hose from the vehicle's heat exchanger to the vehicle engine and insert the T-piece.

Use water hoses to connect the heater and water pump to the thermostat, the non-return valve and T-piece – as shown in the sketch.

#### Heating characteristics – small cooling water circuit

Initially, up to a cooling water temperature of approx. 70 °C, the heater's heat is fed to the vehicle's heat exchanger only – fast heating of the inside of the vehicle.

#### Heating characteristics – large cooling water circuit

If the cooling water temperature continues to rise, the thermostat slowly switches over to the large circuit (full switchover is reached at approx. 75 °C) – heating of the inside of the vehicle and additional engine pre-heating.

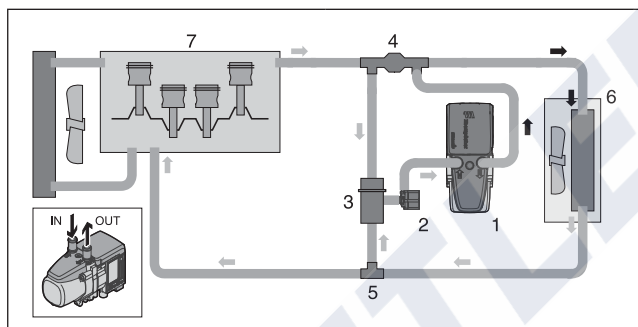

- |                    |                  |
|--------------------|------------------|
| 1 Heater           | 5 T-piece        |
| 2 Water pump       | 6 Heat exchanger |
| 3 Thermostat       | 7 Vehicle engine |
| 4 Non-return valve |                  |

#### **i** NOTE

The thermostat, non-return valve and T-piece must be ordered separately, please refer to the "Product information" document for the Order No.

#### THERMOSTAT FUNCTION

At a coolant liquid water temperature < 70 °C – small cooling water circuit:

- Socket 1 – open (to the heater)
- Socket 2 – open (to the T-piece)
- Socket 3 – closed (to the non-return valve)

At a coolant liquid temperature > 75 °C – large cooling water circuit:

- Socket 1 – open (to the heater)
- Socket 2 – closed (to the T-piece)
- Socket 3 – open (to the non-return valve)

#### **i** NOTE

Use the connections Item (1), (2) and (3) – as shown in the sketch – to integrate the thermostat in the coolant liquid circuit.

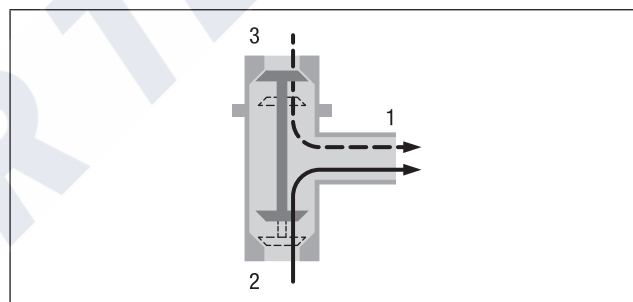

- 1 Connection socket to the heater
- 2 Connection socket to the T-piece
- 3 Connection socket to the non-return valve

#### COOLANT LIQUID CIRCUIT WITH COMBINATION VALVE

##### Using the combination valve with 5 connections

If the water flow line and water return line from the vehicle engine to the vehicle's heat exchanger are laid separately in the engine compartment, the combination valve with 5 connections and an additional T-piece must be used.

##### Using the combination valve with 6 connections

If the water flow line and water return line from the vehicle engine to the vehicle's heat exchanger are laid in parallel in the engine compartment, the combination valve with 6 connections (without T-piece) must be used.

#### Heating characteristic in pre-heater mode – small cooling water circuit

Initially, up to a cooling water temperature of approx. 67 °C, the heater's heat is fed to the vehicle's heat exchanger only – fast heating of the inside of the vehicle.

From a cooling water temperature of approx 67 °C, part of the heater's heat is also passed to the vehicle's engine. This causes additional

### 3 INSTALLATION

engine pre-heating, without rapid cooling of the “small cooling water circuit” for interior heating.

#### Heating characteristic in auxiliary heater mode – large cooling water circuit

While the vehicle's engine is running the heat is distributed between the vehicle's heat exchanger and the vehicle engine – further shortening of the heating up phase and heating of the inside of the vehicle.

#### Install combination valve with 5 connections

Cut the water flow hose from the vehicle engine to the vehicle's heat exchanger and insert the combination valve.

Cut the water return hose from the vehicle's heat exchanger to the vehicle engine and insert the T-piece.

Use water hoses to connect the heater and water pump to the combination valve and T-piece – as shown in the sketch.

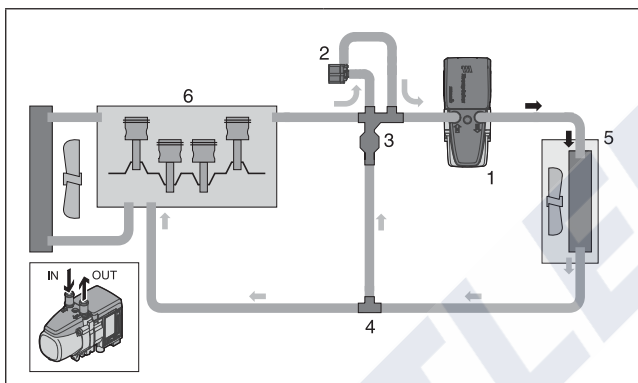

- |                                     |                          |
|-------------------------------------|--------------------------|
| 1 Heater                            | 4 T-piece                |
| 2 Water pump                        | 5 Vehicle heat exchanger |
| 3 combination valve (5 connections) | 6 Vehicle engine         |

#### Install combination valve with 6 connections

Cut the water flow hose and the water return hose from the vehicle engine to the vehicle's heat exchanger and insert the combination valve.

Use water hoses to connect the heater and water pump to the combination valve – as shown in the sketch.

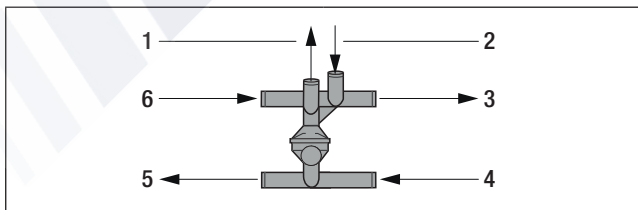

- |                       |                                     |
|-----------------------|-------------------------------------|
| 1 To the water pump   | 4 From the vehicle's heat exchanger |
| 2 From the water pump | 5 To the vehicle engine             |
| 3 To the heater       | 6 From the vehicle engine           |

COOLANT LIQUID WITH 2 NON-RETURN VALVES

#### Preheat the vehicle interior only (vehicle engine uncoupled)

Cut the water flow hose and the water return hose from the vehicle engine to the vehicle's heat exchanger and insert one non-return valve in each.

Insert the heater between the non-return valve and the vehicle's heat exchanger in the water flow hose.

Use water hoses to connect the water pump to the non-return valves.

#### Heating characteristics

If the heater is switched on, the heat is only fed to the vehicle's own heat exchanger. If the coolant liquid temperature reaches approx. 30 °C, the vehicle fan starts and the heat is routed to the passenger compartment.

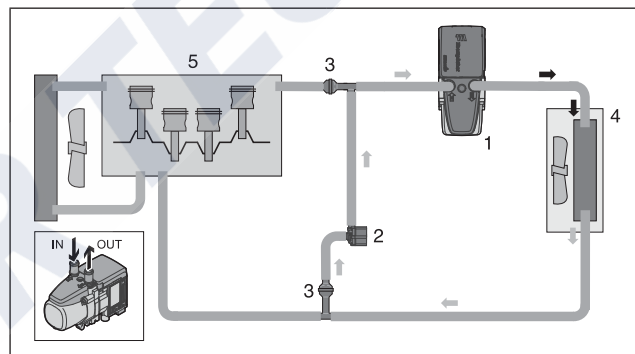

- |                                 |                          |
|---------------------------------|--------------------------|
| 1 Heater                        | 4 Vehicle heat exchanger |
| 2 Water pump                    | 5 Vehicle engine         |
| 3 T-piece with non-return valve |                          |



## 3 INSTALLATION

### EXHAUST SYSTEM



**DANGER!**

**Risk of injuries and burns!**

**Every type of combustion produces high temperatures and toxic exhaust fumes. This is why the exhaust system must always be routed as described in these installation instructions.**

- Do not perform any work on the exhaust system while the heater is working.
- Before working on the exhaust system, switch off the heater first and wait until all the parts have completely cooled down, wear safety gloves if necessary.
- Do not inhale exhaust fumes.



**ATTENTION!**

**The whole exhaust system gets very hot while the heater is running and immediately afterwards. This is why the exhaust system must always be routed as described in these installation instructions.**

- The exhaust pipe must end in the open air.
- The exhaust pipe may not protrude beyond the lateral limits of the vehicle.
- Lay the exhaust pipe sloping slightly downwards. If necessary, make a drain hole with approx.  $\varnothing$  5 mm at the lowest point as a condensation outlet.
- Important functional parts of the vehicle may not be impaired (maintain sufficient clearance).
- Mount the exhaust pipe with sufficient clearance to heat-sensitive parts. Pay particular attention to fuel lines (made of plastic or metal), electrical cables and brake hoses, etc.!
- Exhaust pipes must be safely fixed (recommended clearance of approx. 50 cm) to avoid damage from vibrations.
- Lay the exhaust system so that the outflowing exhaust gases are not drawn in as combustion air.
- The mouth of the exhaust pipe must not become clogged with dirt and snow.
- The mouth of the exhaust pipe must not point in the direction of travel.
- Always fix the exhaust silencer to the vehicle.
- Lay the exhaust system so that the exhaust fumes do not flow directly onto heat-sensitive components.

### **i** NOTE

- Note and follow the regulations and safety instructions for this chapter [from page 8](#).
- The exhaust pipe end should be much shorter than the flexible exhaust pipe from the heater to the exhaust silencer.
- To avoid contact corrosion, the clips for fixing the exhaust pipe must be made of stainless steel. For the Order No. of the fixing clips, please refer to the "Product Information" document.

The exhaust system consists of a flexible exhaust pipe,  $\varnothing$  24 mm, 900 mm long, a flexible exhaust pipe end with end sleeve,  $\varnothing$  24 mm, 300 mm long and an exhaust silencer.

All parts for the exhaust system including the fixing parts are included in the installation kit (for allowable line lengths, see sketch [on page 23](#)).

### INSTALLING THE EXHAUST SYSTEM

Use a bracket to fix the exhaust silencer in a suitable place on the vehicle (see sketch).

Lay the flexible exhaust pipe from the heater to the exhaust silencer and fasten with pipe clips (tightening torque  $6^{+0.5}$  Nm), adjust the length if necessary.

If necessary, shorten the exhaust pipe end with end sleeve, push onto the exhaust silencer and fix with a pipe clip (tightening torque  $6^{+0.5}$  Nm). If necessary, use pipe clips to fasten the flexible exhaust pipe and the exhaust pipe end in suitable positions in the vehicle (recommended guide value at approx. 50 cm spacings).

If necessary attach spacer rings on the flexible exhaust pipe and onto the exhaust pipe end, to ensure a safe distance from heat-sensitive parts of the vehicle. If applicable, use additional exhaust pipe insulation (see product information).

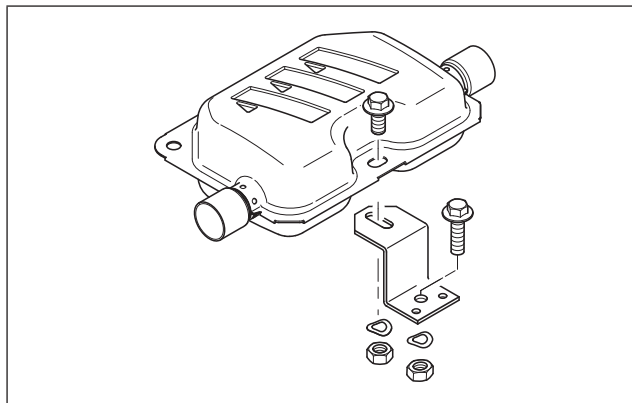

## 3 INSTALLATION

### COMBUSTION AIR SYSTEM

#### ATTENTION!

#### Safety instructions for the combustion air system

- The combustion air opening must remain free at all times.
- Lay the combustion air intake to ensure that exhaust fumes cannot be drawn in as combustion air.
- Do not direct the combustion air intake against the vehicle's airstream.
- The combustion air intake must not become clogged with dirt and snow.
- Install the combustion air intake system sloping slightly downwards. If necessary, make a drain hole approx.  $\varnothing$  5 mm at the lowest point to drain off condensation.
- If necessary, use fastening clips or cable ties to fix the flexible combustion air hose to the vehicle in suitable places.

#### INSTALLING THE COMBUSTION AIR SYSTEM

A combustion air intake silencer with flexible pipe,  $d_i = 20$  mm, 760 mm long, is included in the installation kit.

Push the flexible pipe from the combustion air intake silencer onto the combustion air connection socket of the heater and fix with a hose clip (tightening torque  $3^{+0.5}$  Nm).

Lay the combustion air intake silencer so that the combustion air is removed from an area, which fulfils the named conditions.

If necessary, the flexible pipe from the combustion air intake silencer can be shortened according to the installation conditions.

When shortening the flexible pipe, ensure the cutting edge is clean, small cut-off pieces could block the combustion air fan.

#### NOTE

Note and follow the regulations and safety instructions for this chapter [from page 7](#).

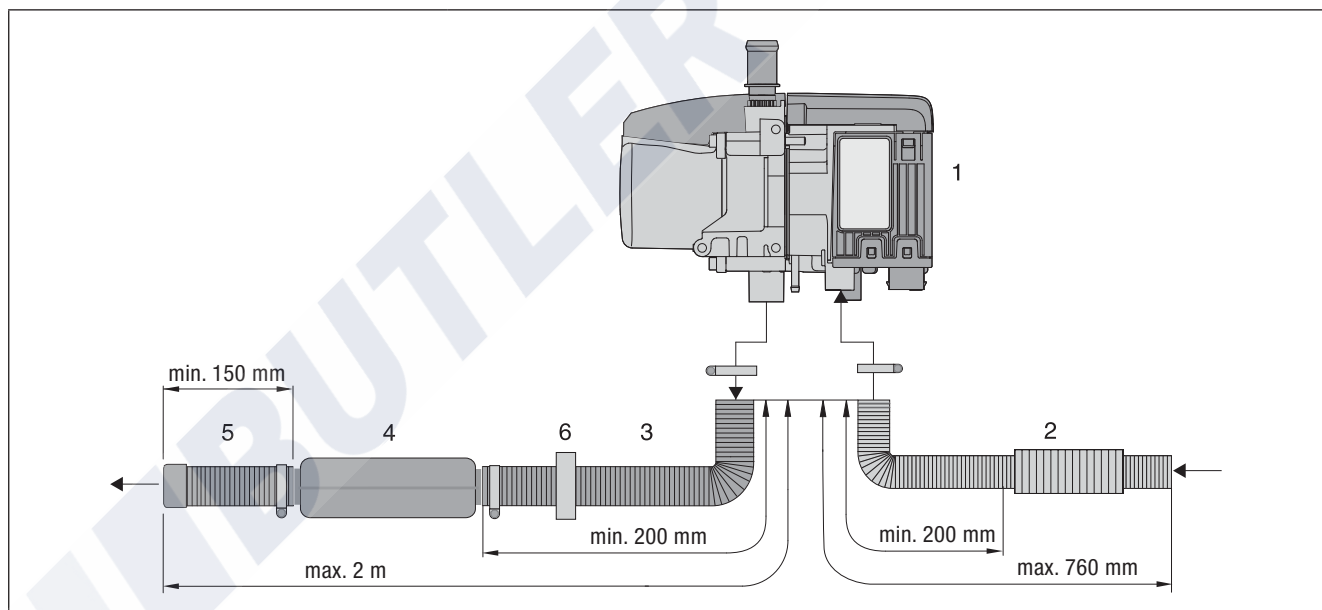

- |                                  |                                    |
|----------------------------------|------------------------------------|
| 1 Heater                         | 4 Exhaust silencer                 |
| 2 Combustion air intake silencer | 5 Exhaust pipe end with end sleeve |
| 3 Flexible exhaust pipe          | 6 Spacer ring                      |

### 3 INSTALLATION

#### FUEL SUPPLY



**DANGER!**

**Risk of fire, explosion, poisoning and injury!**

**Caution when handling fuel.**

- Switch off the vehicle engine and the heater before refuelling and before working on the fuel supply.
- Avoid naked flames when handling fuel.
- Do not smoke.
- Do not inhale petrol fumes.
- Avoid any contact with the skin.



**ATTENTION!**

**Always note and follow the safety instructions when installing the metering pump and when laying the fuel lines.**

**Deviations from the instructions stated here are not allowed.**

**Failure to comply can result in malfunctions.**

- To install the fuel hose at the heater, moisten it and push it carefully onto the fuel connection socket.
- Use a sharp knife only to trim the fuel hoses and pipes. Interfaces must not be crushed and must be free of burrs.
- Wherever possible, lay the fuel lines from the metering pump to the heater with a continuous rise.
- Fuel lines must be securely fixed to avoid damage and / or noise due to vibrations (recommended guideline value: clearance of around 50 cm).  
Especially in electric vehicles, ensure that the fuel lines are fixed so that sound transfer to the vehicle is prevented.
- Fuel lines must be protected against mechanical damage.
- Lay the fuel lines so that any twisting of the vehicle, engine movements, etc. do not have a disadvantageous effect on their durability.
- Use hose clips to secure all hose connections in the fuel supply.
- Parts carrying fuel must be protected from interfering heat.
- Never route or fasten the fuel lines directly along the heater or vehicle exhaust system.
- When systems cross, always ensure there is a sufficient heat clearance. If necessary, attach heat deflection plates.
- Dripping or evaporating fuel must never be allowed to collect on hot parts or ignite on electric equipment.

- When connecting fuel lines with a fuel hose, always install the fuel lines with a butt joint to prevent any bubbles from forming.

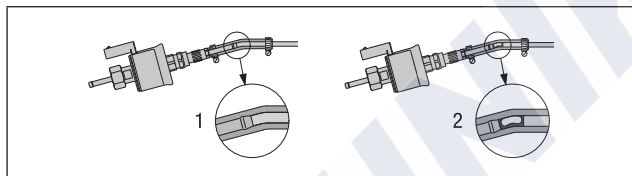

- 1 correctly laid lines
- 2 incorrectly laid lines – bubbles form



**ATTENTION!**

**Safety instructions for fuel lines and fuel tanks in buses and coaches!**

- In buses and coaches, fuel lines and fuel tanks must not be routed through the passenger compartment or driver's cab.
- Fuel tanks in buses and coaches must be positioned in such a way that the exits are not in immediate danger if a fire occurs.



**NOTE**

- The installation kit contains all parts required for the fuel supply.
- Note and follow the regulations and safety instructions for this chapter [from page 7](#).
- Sound insulation and abrasion protection: sponge rubber hose for fuel lines available separately as an accessory (see product information).

### 3 INSTALLATION

FUEL EXTRACTION WITH TANK CONNECTION OR WITH ADAPTER – FOR PETROL AND DIESEL VEHICLES

**⚠ ATTENTION!**

**Fuel supply safety instructions!**

**The fuel must not be conveyed by means of gravity or overpressure in the fuel tank.**

- The fuel may only be pumped by the metering pump included in the scope of supply and approved by the manufacturer.

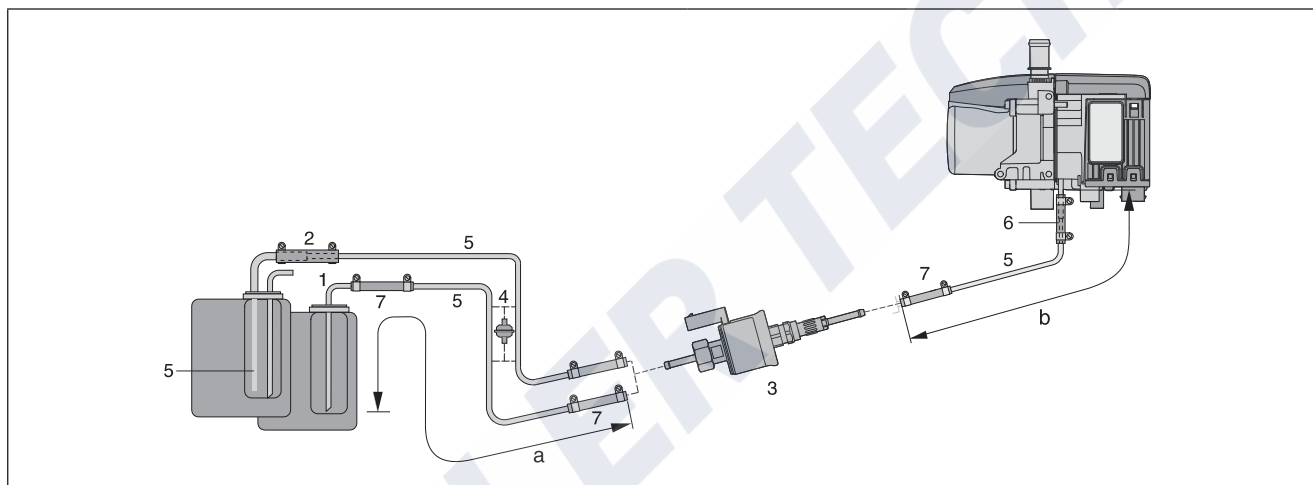

- 1 Tank connection,  $d_i = \varnothing 2 \text{ mm}$ ,  $d_a = \varnothing 4 \text{ mm}$  – installed in the vehicle's own tank fitting
- 2 Adapter,  $\varnothing 7.5 / 3.5 \text{ mm}$  – connected to the vehicle's own tank fitting, at a connection socket  $\varnothing 8 \text{ mm}$ , used to pass through the intake line (fuel pipe  $4 \times 1$ ) up to just before the bottom of the tank.
- 3 Metering pump
- 4 Fuel filter – only required for contaminated fuel
- 5 Fuel pipe,  $4 \times 1$  ( $d_i = \varnothing 2 \text{ mm}$ )
- 6 Adapter,  $\varnothing 4.5 / 3.5 \text{ mm}$
- 7 Fuel hose,  $3.5 \times 3$  ( $d_i = \varnothing 3.5 \text{ mm}$ ), approx. 50 mm long

**Permissible line lengths**

**Intake side**

$a = \text{max. } 2 \text{ m}$

**Pressure side**

$b = \text{max. } 6 \text{ m}$

**i NOTE**

- Connect fuel pipe,  $4 \times 1$ , (Item 5) to the heater using adapter,  $\varnothing 4.5 / 3.5 \text{ mm}$ , (Item 6).
- Item 5 is not included in the "Installation kit" scope of supply. Order No. [see page 10](#).
- Installation of the fuel filter (Item 4) requires two adapters  $\varnothing 5 / 3.5 \text{ mm}$ , Order No. [see page 10](#).
- Use two hose clips  $\varnothing 11$  to secure the adapter  $\varnothing 7.5 / 3.5 \text{ mm}$  (Item 2) (tightening torque:  $1^{+0.2} \text{ Nm}$ ).
- When installing tank connection (Item 1), maintain a minimum distance of  $5^{\pm 2} \text{ mm}$  from the end of the riser to the bottom of the tank.

### 3 INSTALLATION



**ATTENTION!**

**Metering pump installation safety instructions!**

- Always install the metering pump with the delivery side rising upwards – minimum angle 15°.
- Do not install the metering pump and filter near silencers and exhaust pipes and therefore protect against unacceptable heating (petrol max. 20 °C, diesel max. 50 °C).

**METERING PUMP INSTALLATION**

Always install the metering pump with the delivery side rising upwards. Any mounting position between 15° and 90° is allowed, although a mounting position between 15° and 35° is preferable.

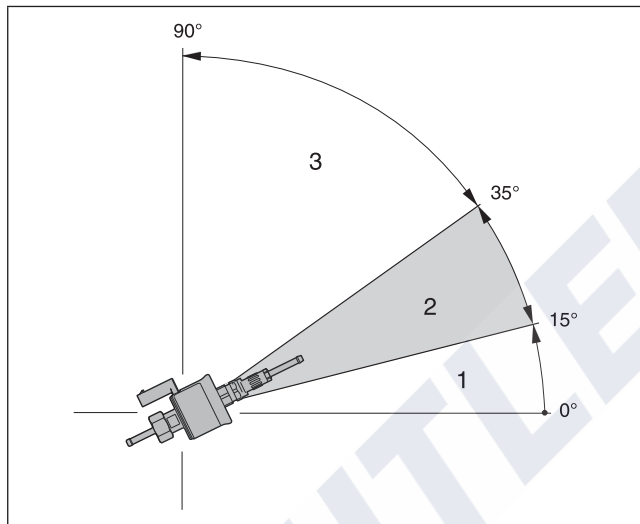

- 1 Installation position between 0° – 15° is not allowed
- 2 Preferred installation position within range 15° – 35°
- 3 Installation position within the range 35° to 90° is allowed

**PERMISSIBLE SUCTION AND PRESSURE HEAD OF THE METERING PUMP**

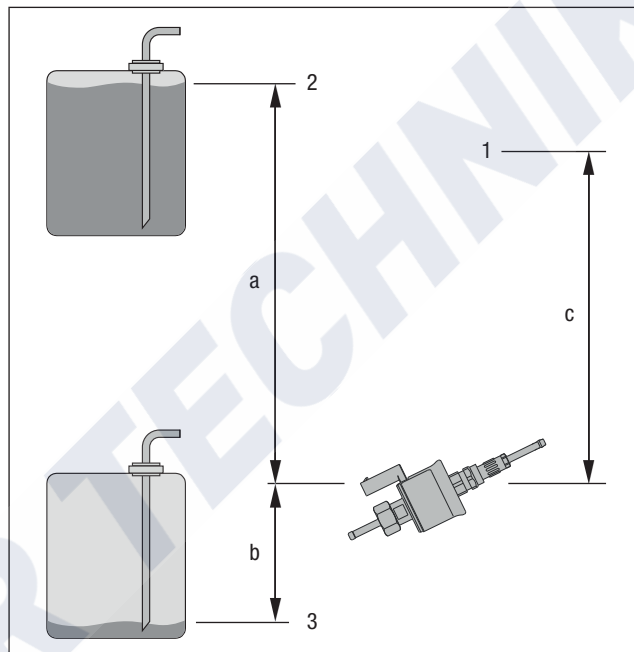

- 1 Connection at the heater
- 2 max. fuel level
- 3 min. fuel level

Pressure head from vehicle tank to metering pump:

a = max. 3000 mm

Suction head in pressure-less vehicle tank:

- b = max. 500 mm for petrol
- b = max. 1000 mm for diesel

Suction head in a vehicle tank in which negative pressure occurs during extraction (valve with 0.03 bar in the tank cap):

- b = max. 150 mm for petrol
- b = max. 400 mm for diesel

Pressure head from the metering pump to the heater:

c = max. 2000 mm



**NOTE**

Check tank ventilation.

## 3 INSTALLATION

### FUEL QUALITY FOR PETROL HEATER

The heater runs problem-free on standard commercially quality fuel, which you use to run your vehicle engine. Commercially available maximum addition of ethanol to DIN 51600 and DIN EN 228.

#### **i** NOTE

Heaters B 4 E and B 5 E are **not** approved for operation with ethanol fuel E85 to DIN 15293.

---

### FUEL QUALITY FOR DIESEL HEATER

- The heater runs problem-free on standard commercial quality diesel fuel, which you use to run your vehicle engine. Commercially available maximum addition of biodiesel to EN 590.

During the winter months the diesel fuel is adapted to the low temperatures of 0 °C to –20 °C.

This means that problems can only arise if extreme drops in temperature occur – as is the case for the vehicle engine too – please refer to the vehicle manufacturer's instructions.

- In special cases and at outdoor temperatures above 0 °C the heater can also be run on EL heating oil according to DIN 51603 (from an additional tank).
- If the heater is run from a separate tank, please comply with the following rules:
  - at outside temperatures above 0 °C, use diesel fuel to EN 590 or EL heating oil to DIN 51603;
  - at outside temperatures of 0 °C to –20 °C, use winter diesel fuel to EN 590;
  - at outside temperatures of –20 °C to –40 °C, use Arctic diesel or polar diesel.

#### **i** NOTE

- It is **not** permitted to add used oil!
  - Following operation with winter or cold diesel, the fuel lines and the metering pump must be filled with the standard diesel fuel after letting the heater run for 15 minutes!
  - Heaters B 4 E and B 5 E are **not** approved for operation with biodiesel to DIN 14214.
-